



BRAGA MORO
SISTEMI DI ENERGIA

UNI EN ISO 9001-2015 n° 9115.BRMO

UPS OCTANS 10/20kVA 3:1 USER MANUAL



BRAGA MORO
SISTEMI DI ENERGIA

VIA LUDWING VAN BEETHOVEN N.24

20090 CINISELLO BALSAMO (MI)

Tel.: +39 0251672201

Fax: +39 0251672213

Mail: sales@bragamoro.com

www.bragamoro.com

USER MANUAL

OCTANS PLUS 15/20kVA 3:1

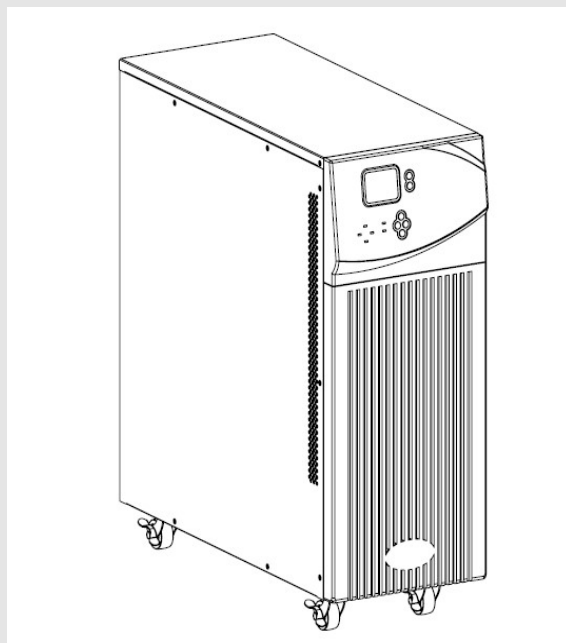

File name	Date	Page	Code	PUV9E010/15/20-AK
DF19010A	10/04/2019	1 di 28		

INDEX

1	DOCUMENT CHECK SECTION.....	3
2	Safety instructions.....	5
2.1	Prohibitions.....	5
3	Safety tips.....	5
4	Production Introduction.....	6
4.1	Application.....	6
4.2	1.2 Product range.....	6
4.3	1.3 System principle diagram.....	6
4.4	Features.....	7
4.5	Product overview.....	7
4.5.1	Product view.....	7
4.5.2	Rear panel instruction.....	8
5	Installation.....	9
5.1	Unpack checking.....	9
5.2	Installation procedure.....	9
5.2.1	Installation note.....	9
5.2.2	Installation.....	10
5.3	Connection of parallel system.....	12
6	Operation.....	13
6.1	Working modes.....	13
6.1.1	AC mode.....	13
6.1.2	Bypass mode.....	13
6.1.3	Battery mode.....	13
6.1.4	ECO mode.....	13
6.2	Panel display, operation and running.....	14
6.2.1	Start up and turn off the UPS.....	14
6.2.2	Faceplate display.....	15
3	Display instruction.....	17
6.3	Working Mode and transferring.....	20
6.3.1	Transfer to bypass if overload.....	20
6.3.2	Normal mode to battery mode.....	20
6.3.3	Go to bypass mode due to over temperature.....	20
6.3.4	Output short circuit.....	20
6.3.5	Batter self-Test.....	20
6.4	UPS monitoring.....	20
6.5	Display Messages/ Records.....	20
6.5.1	Operational Status and Mode(s).....	21
6.5.2	Alarm Information.....	21
7	Specification.....	23
8	Maintenance.....	25
8.1	Fan maintenance.....	25
8.2	Battery maintenance.....	25
8.3	Visual checking.....	25
8.4	UPS status checking.....	25
9	Trouble shooting.....	26
10	Appendix I USB communication port definition.....	27
11	Appendix II RS232 communication port definition.....	28

File name	Date	Page	Code	PUV9E010/15/20-AK
DF19010A	10/04/2019	2 di 28		



1 DOCUMENT CHECK SECTION

Drawing

Written by	Role	Date
David Alessandri	Technical Staff	10/04/2019

Control

Controlled by	Role	Date
David Alessandri	Technical Staff	10/04/2019

Approved

Approved by	Role	Date
Adelio Abbondio	Technical Staff	10/04/2019

Revision

Rev.	Author	Description	Date
B			
C			
D			
E			
F			
G			
H			
I			
L			

References

Ref.	Author	Title	Revision

File name	Date	Page	Code	PUV9E010/15/20-AK
DF19010A	10/04/2019	3 di 28		



SAFETY AND RESPONSIBILITY

THIS MANUAL IS PART OF THE RELEASED DEVICE.

THE KNOWLEDGE OF THIS DOCUMENT IS COMPULSORY TO HANDLE OR USE THE UNIT.

THE MANUAL COMPLIES WITH THE TECHNICAL REVISION OF THE UNIT AT THE DATE OF PRINTING.

THE CONTENT IS PURELY INFORMATION PURPOSE AND DOES NOT REFER TO THE CONTRACT. DUE TO THE TECHNICAL EVOLUTION OF THE PRODUCT, POSSIBLE DIVERGENCES BETWEEN THE CONTENTS OF THE MANUAL AND THE RELEASED PRODUCT.

THE MANUFACTURER IS NOT RESPONSIBLE FOR THE CORRECTNESS OF THE TECHNICAL DESCRIPTION OR THE DATA SHOWN, BECAUSE THERE IS NO OBLIGATION FOR THE PERMANENT UPDATE OF THIS DOCUMENTATION.

BEFORE INSTALLING OR OPERATING THIS EQUIPMENT READ THE INSTRUCTIONS CONTAINED IN THIS MANUAL CAREFULLY AND MAKE SURE THEY ARE RESPECTED BY TECHNICAL PERSONNEL.

KEEP THIS MANUAL CLOSE TO THE EQUIPMENT FOR EVERY FUTURE REFERENCE.

ALL MAINTENANCE WORKS MUST BE CARRIED OUT BY QUALIFIED PERSONNEL, RESPECTING ACCIDENT PREVENTION REGULATIONS RELATED TO THE COUNTRY OF USE AND INTERNATIONAL.

OPENING OR REMOVING THE EQUIPMENT PROTECTIONS YOU MAY COME IN CONTACT WITH DANGEROUS VOLTAGES!

DISPERSION CURRENTS

MAKE SURE THAT THE GROUNDING IS PERFORMED CORRECTLY BEFORE CONNECTING THE DEVICE TO THE NETWORK!

PACKING

THE DISINFAL AND INSTALLATION OPERATION MUST BE CARRIED OUT WITH THE MAXIMUM ATTENTION AVOIDING OVERTURNING AND SHAKES IN ORDER TO DO NOT COMPROMISE THE CORRECT OPERATION.

TO AVOID DAMAGE CAREFULLY FOLLOW THE INSTALLATION AND COMMISSIONING PROCEDURE.

File name	Date	Page	Code	PUV9E010/15/20-AK
DF19010A	10/04/2019	4 di 28		



2 Safety instructions

2.1 Prohibitions

1. There is a risk of electric shock inside the UPS. **DO NOT REMOVE** the external panels of the appliance without first contacting the technical assistance of BRAGA MORO SpA.
2. Contact the distributor before using the UPS to power on:
 - electromedical equipment;
 - equipment that can damage people in case of malfunction.
3. Do not dispose of the batteries if they are not from an authorized company and do not store them near heat sources.

3 Safety tips

1. The output of the UPS with internal batteries can be live even if not connected to the power supply (Battery operation).
2. Make sure the UPS is completely shut down before making connections or reconfiguration of the connections.
3. **MAKE SURE THE EARTH CONNECTIONS ARE WELL DONE BEFORE TURNING THE UPS ON.**
4. The operating and storage environment may affect the reliability of the UPS.
5. Avoid placing the UPS and operating it in the following environments:
 - Areas with temperatures and humidity outside the range stated in the specifications on page 29;
 - Areas where the UPS is exposed to direct sunlight or near other heat sources;
 - Areas with the presence of corrosive and / or flammable gases;
 - Areas with high dust content.
6. Place the UPS so as to guarantee the flow of fresh air to the fans, in case of overtemperature the UPS protects itself and carries the loads on the Bypass line;
7. Do not place liquid containers on top of the UPS;
8. In the event of a fire in the UPS room, use only powder extinguishers;
9. In environments with high temperatures the life of the batteries is significantly reduced, the test and the possible periodic replacement of the batteries maintains the characteristics of back up constant;
10. In the case of a higher storage and 3 months it is recommended to connect the UPS to the mains and carry out a charge of at least 12 hours before storing them again;

File name	Date	Page	Code	PUV9E010/15/20-AK
DF19010A	10/04/2019	5 di 28		

4 Production Introduction

4.1 Application

This series UPS, providing reliable AC power to various equipment, can be used for computer center, network management center, auto control system, telecom systems, etc.

4.2 Product range

This series contains many capacities of UPS products.

The UPS models and configuration of 10 k; 15 k; 20 k are as follows.

Capacity	10kVA	15kVA	20kVA
Model	10k	15k	20k
Remarks	Standard model, External battery	Standard model, External battery	Standard model, External battery

4.3 System principle diagram

The system can work as a single unit or parallel one, so as to enhance its reliability.

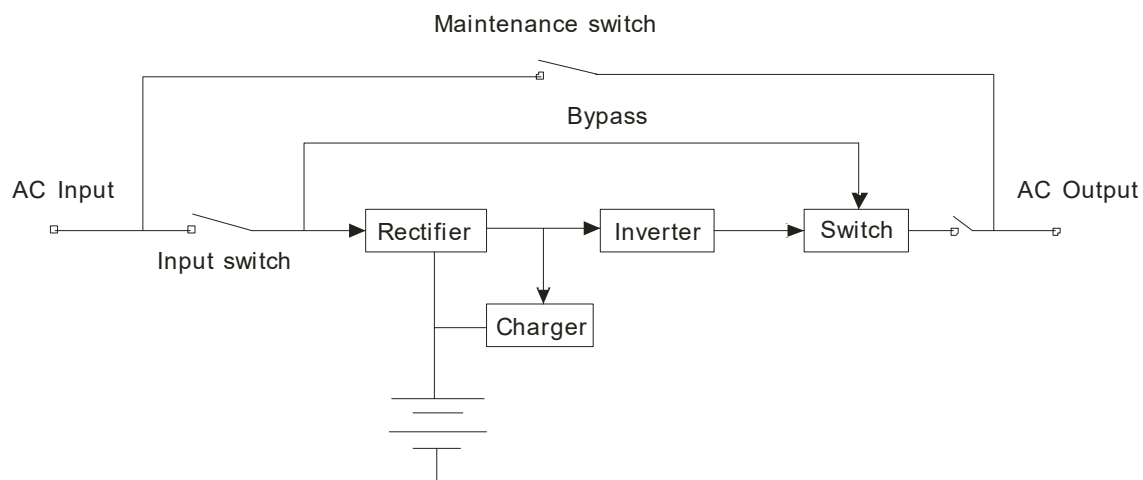

Fig.4-3 1 Single unit

File name	Date	Page	Code	PUV9E010/15/20-AK
DF19010A	10/04/2019	6 di 28		

4.4 Features

This series is newly introduced. It is an intelligent online sine wave UPS.

- High frequency, double conversion, high input power factor, wide input voltage range, the output will not be disturbed by power network, suitable for area with poor power supply condition
- DSP technology for all-digital control, high reliability, self-diagnostics and protections are featured
- Intelligent battery management which extends battery life
- LCD panel and LED indicators clearly indicate the system status and parameters such as input/output voltage, frequency, load, temperature inside UPS, etc.
- Perfect network power management can be achieved by using UPS monitoring software
- Maintenance bypass switch is provided so the power supply to load will not be interrupted during repair

4.5 Product overview

4.5.1 Product view

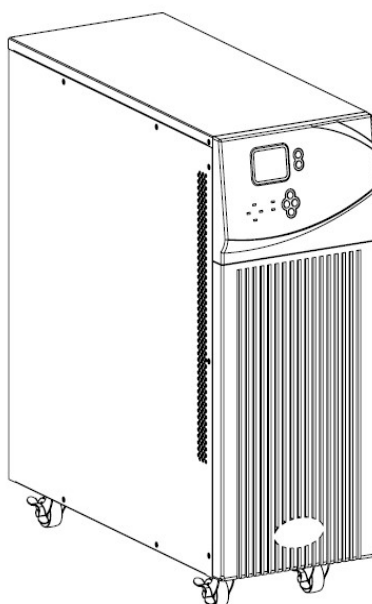

Fig. 4-5 1 Complete unit view

File name	Date	Page	Code	PUV9E010/15/20-AK
DF19010A	10/04/2019	7 di 28		

4.5.2 Rear panel instruction

4.5.2.1 10/15/20k(H) Rear panel

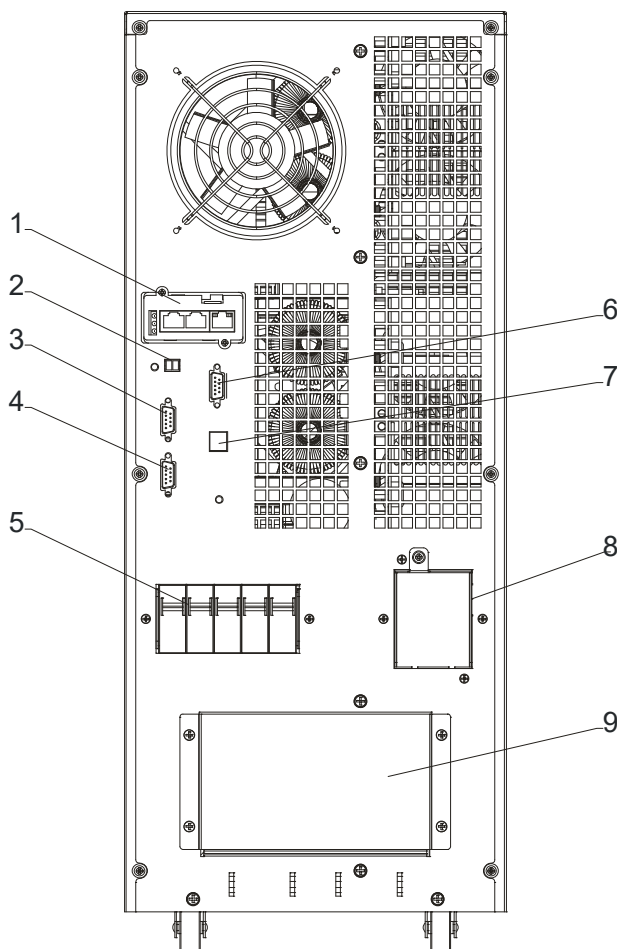

Fig.4-5 2a 10/15/20 k (H) Rear Instruction

- 1) Intelligent slot
- 2) EPO (External Power Off)
- 3) Parallel port 1
- 4) Parallel port 2
- 5) Input & output breaker
- 6) COM
- 7) USB
- 8) Maintenance bypass switch (covered)
- 9) Terminals (covered)

File name	Date	Page	Code	PUV9E010/15/20-AK
DF19010A	10/04/2019	8 di 28		

5 Installation

5.1 Unpack checking

- 1) Don't lean the UPS when moving it out from the packaging.
- 2) Check the appearance to see if the UPS is damaged during transportation, do not switch on the UPS if any damaged is found and please contact the dealer.
- 3) Check the accessories according to the packing list and contact the dealer if any parts missing.

5.2 Installation procedure

5.2.1 Installation note

- Put the UPS at flat place next to the equipment.
- Keep the UPS at least 20cm from wall or equipment or other object. Don't block the ventilation holes of the UPS located in the front panel and the bottom part, so as to keep the ventilation in good condition & avoid temperature of components inside getting high.
- Keep the UPS away from high temperature, water, flammable gas, corrosive gas, dust, direct sunlight and explosive things
- Don't lay the UPS outdoor.
- 3P 125A/400V circuit breaker is required at the input and battery and 2P 125A/400V is required at the output.
- PDU is required to connect to the UPS output so as to weaken the affection between loads
- In order to fix the UPS, please lock its wheels by shifting the sheet on each wheel.
- RCD load like computer, linear load and small inductive load can be connected with the UPS. Please contact dealer if other types of loads is required to be connected with.
- For the safety sake of user and equipment's, please betake correct power configuration.

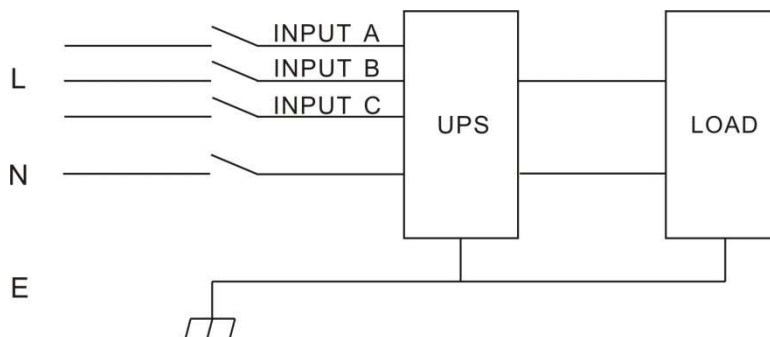

Fig.5-1 Correct power configuration

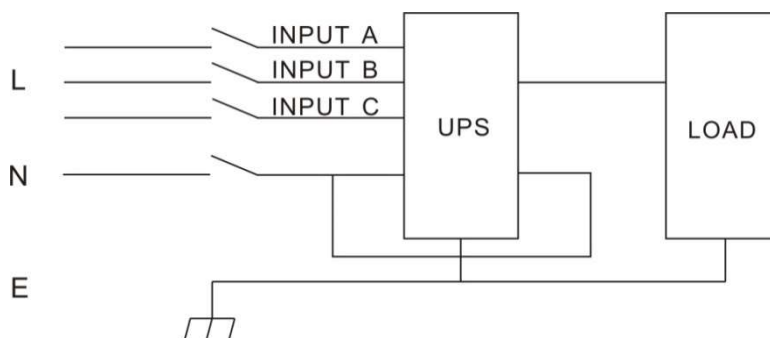

Fig.5-2 Wrong power configuration

File name	Date	Page	Code	PUV9E010/15/20-AK
DF19010A	10/04/2019	9 di 28		

5.2.2 Installation

5.2.2.1 External battery connection (for extended model only)

- 1) Make sure battery quantity complies with the specs (16 to 20 pieces of 12V battery in series) . Measure the voltage of battery bank after finishing connection.

CAUTION!

Don't mix batteries with different capacity & brands and don't mix brand new and old batteries, either.

- 2) The breaker on battery cabinet should be off.
- 3) Take out the connection box and remove the cover of terminals, use multi-meter to make sure there is no DC voltage at the battery terminals of UPS.
- 4) Connect battery pole with positive pole, common pole and negative pole to battery connector (BAT+,BATN,BAT-) , don't reverse battery connection.

CAUTION!

It is recommended to connect or replace battery after switching off the system; don't reverse battery polarity when doing battery hot-swapping.

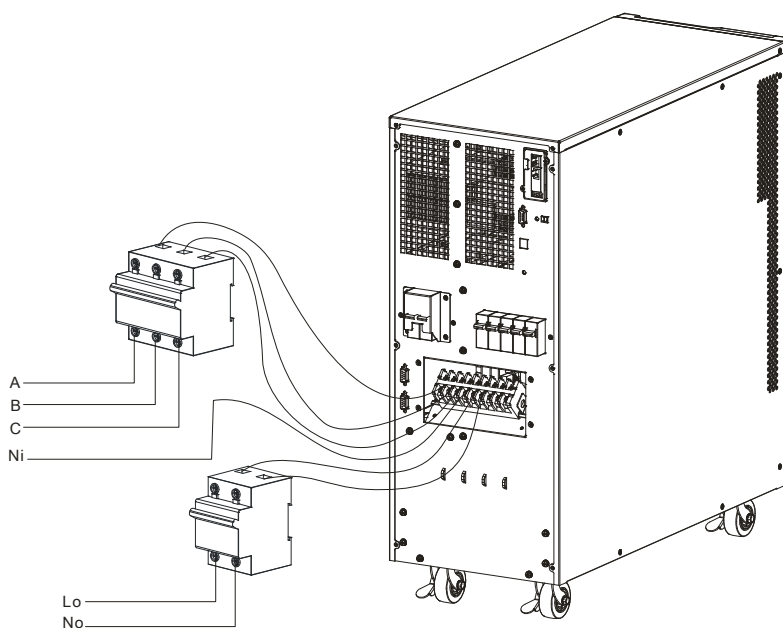

Fig.5-3a 10k(S) External battery connection

File name	Date	Page	Code	PUV9E010/15/20-AK
DF19010A	10/04/2019	10 di 28		

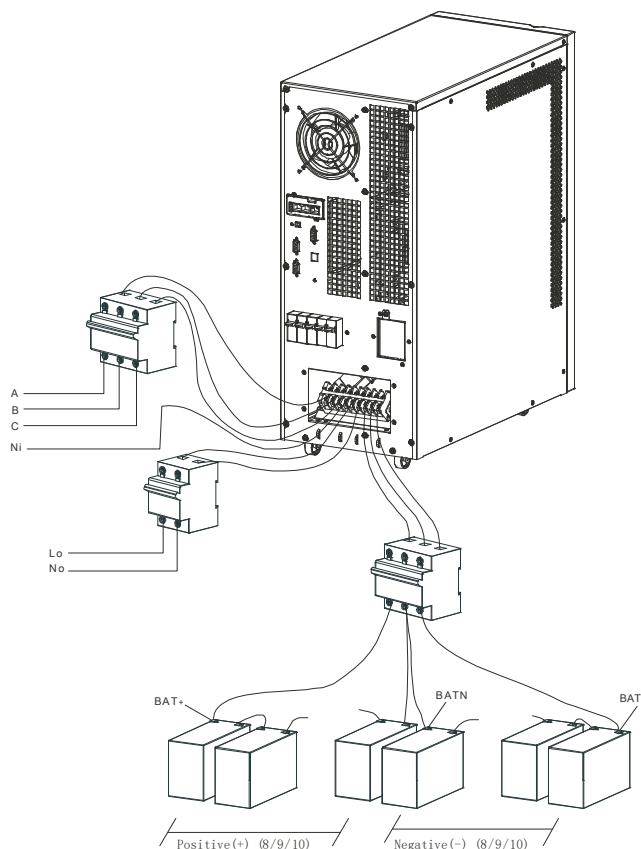

Fig.5-3b 10k/15k/20k(H) External battery connection

5.2.2.2 UPS input and output connection

Minimum 8AWG or 10 mm² copper wires for input/output & battery cables are required for the ups.

- Switch off all breakers before connecting cables.
- Remove the cover of the terminals, see Fig 2-4, and connect the cables correspondingly

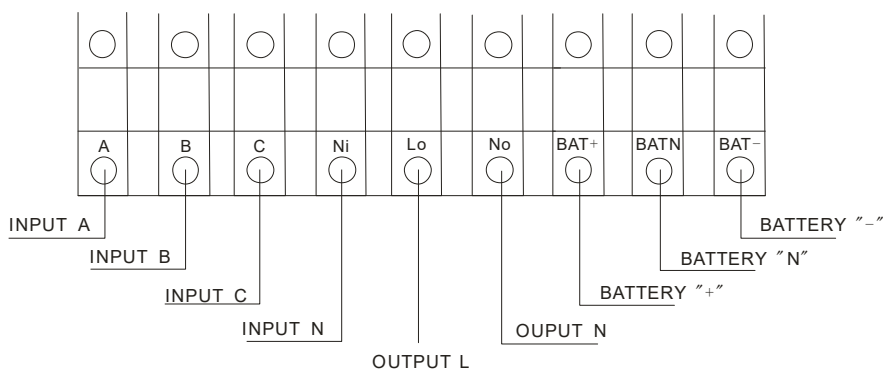

Fig. 5-4a 10k/15k/20k I/O terminals connection

File name	Date	Page	Code	PUV9E010/15/20-AK
DF19010A	10/04/2019	11 di 28		

CAUTION!

Terminators are required so as to ensure the connections are firm
Don't reverse the input L and N
Don't connect the UPS input to a wall outlet or the outlet will get burnt.

- Connect the UPS output L, N, E to L, N, E of load via a PDU. Tighten the screws and shelter the terminals

CAUTION!

Please connect the output Earth well before go for other operation

5.2.2.3 Connection of the UPS communication cables

1. USB cable provided in accessories can be used to connect the UPS with PC
2. Follow steps below to install SNMP (if purchased):
 - a. Remove the cover of SNMP slot at UPS rear panel and keep it for further use.
 - b. Insert the SNMP card and tighten the screws
 - c. Connect the UPS with internet by network cable.
3. Refer to the SNMP manual provided to do SNMP setting.

5.3 Connection of parallel system

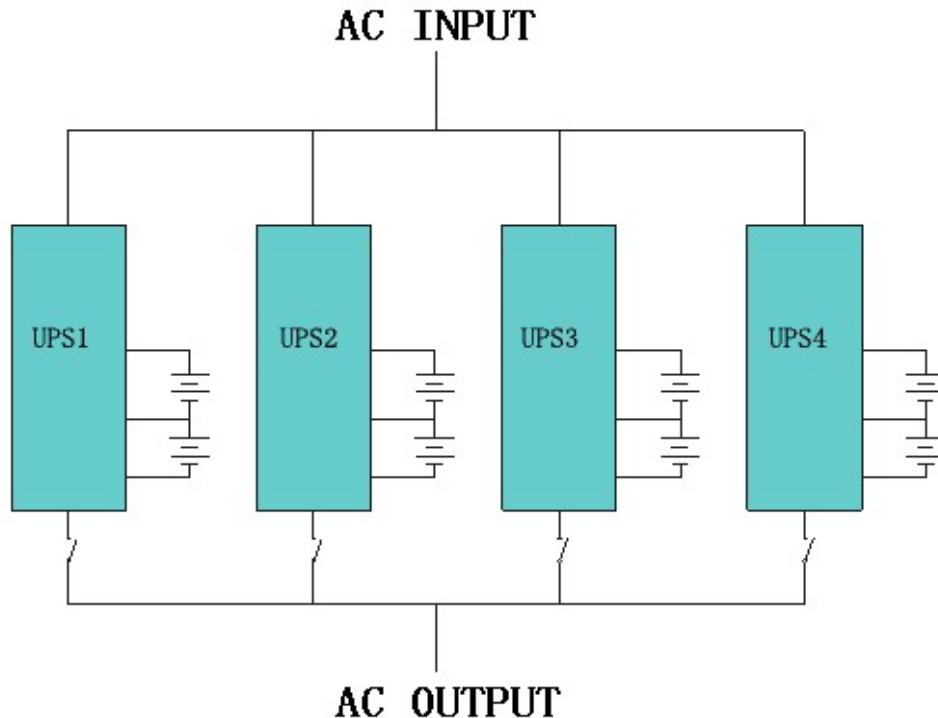

Fig.5-5 parallel system

Make sure all the breakers are off and no output at the UPS output.

File name	Date	Page	Code	PUV9E010/15/20-AK
DF19010A	10/04/2019	12 di 28		



CAUTION!

Connect the A/B/C/N/L and E well

Wire for requirement:

For 10KVA UPS, select 10AWG or 6mm² I/O copper line. The total line length is N*6mm².

For 15KVA UPS, select 8AWG or 10mm² I/O copper line. The total line length is N*10mm².

For 20KVA UPS, select 6AWG or 16mm² I/O copper line. The total line length is N*16mm².

(N equals the numbers of the UPS in parallel.)

6 Operation

6.1 Working modes

The UPS has AC mode, bypass mode, battery mode and ECO mode

6.1.1 AC mode

If the AC input and load capacity are in normal ranges, the load will be powered by inverter output, battery will be charged at the same time. AC and inverter indicators on LCD control panel will be on (green).

CAUTION!

Please note below if the UPS input power is provided by a generator.

1) Don't switch on the loads before starting UPS. After the UPS has been started and worked steadily, switch on the loads one by one. Suggest that the total capacity of the loads should be lower than 30% of capacity of the generator.

2) It is suggested that the rating of generator should be 1.5-2 times of the capacity of the UPS.

6.1.2 Bypass mode

When the AC power is connected and the UPS has not been switched on, or the UPS is overloaded after switching on the UPS, it will go to bypass mode. The Loads will be powered by AC, battery will be charged, and the bypass indicator on the LCD control panel will be on (yellow). But, if the bypass is beyond normal range or absent, the UPS will not go to bypass mode and no power will be supplied to the loads.

6.1.3 Battery mode

In AC mode, if the AC is absent or beyond normal range, the rectifier and charger will stop working, the loads will be powered by battery bank of which energy goes through inverter circuit. The Inverter's and battery's indicators on LCD control panel will be on (green) and the alarm will beep every 2 seconds.

In battery mode, if the battery voltage becomes low and reaches the setting value, the system will give low battery voltage alarm, beep once every second and the LCD will give low battery alarm, too.

CAUTION!

Charge batteries for at least 8 hours when the UPS is used at the first time, as battery

6.1.4 ECO mode

In AC mode, the UPS can be set to work in ECO mode if the load does require strict power purity and it can be sustained in bypass mode normally. If the AC is beyond normal range, the UPS will transfer back to inverter mode. The Efficiency for the UPS in ECO mode is much higher.

File name	Date	Page	Code	PUV9E010/15/20-AK
DF19010A	10/04/2019	13 di 28		

6.2 Panel display, operation and running

The operation is simple, operators only need to read the manual and follow the operation instructions listed in this manual, no need any special training.

6.2.1 Start up and turn off the UPS

➤ Start up operation

1. Turn on the UPS in Line mode

Once AC Power Cord is plugged in, the UPS will start automatically and the LCD display of the UPS will be lit on. You may view the data and set parameters on the LCD display as well as the LED display showing the status of the UPS.

2. Turn on the UPS in Battery Mode

Press "On" on the front panel to start the UPS and in the meantime, the LCD display will light up. You may view the data and set parameters on the LCD display and the LED display of the UPS will show the latest status of the UPS.

➤ Turn off operation

1. Turn off the UPS in line mode (without batteries)

① Press and hold the OFF key for 2 seconds to turn off the inverter and the UPS is in Bypass mode now; on the contrary, you may press the hold the OFF key for 2 seconds in order to Change over back to inverter mode.

② To shut down (turn off) the UPS completely, you need to turn off the input switch.

2. Turn off the UPS with connecting batteries

① Press and hold the OFF key for 2 seconds to turn off the UPS.

② After UPS is turned off, all LED and LCD will be extinguished and there is no output.

Remarks: When the UPS is turned off from the inverter mode, it will discharge DC Bus and then shut down completely; therefore, sometimes, it takes more several seconds to complete.

File name	Date	Page	Code	PUV9E010/15/20-AK
DF19010A	10/04/2019	14 di 28		

6.2.2 Faceplate display

➤ Faceplate display illumination

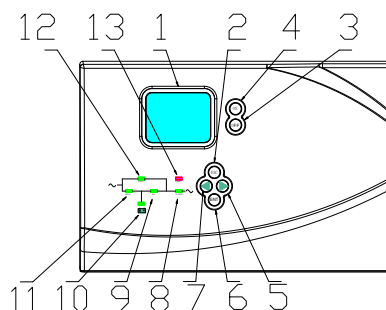

Fig.6.2.2° Overview of the operating panel of the UPS

1. LCD Display Board
2. ESC
3. Off button
4. On button
5. right or down
6. Enter
7. Left or up
8. Output indicator
9. Inverter Indicator
10. Battery Indicator
11. Mains (AC) Indicator
12. Bypass Indicator
13. Fault Indicator

➤ LCD display

1、LED indicator definition

- 1) Fault Indicator (red) : "On" indicates when a fault occurred; "Off" means no fault occurred.
- 2) Indicator (Green) : "On" means AC is normal, "Off" means AC is not present, and blinking means voltage is beyond normal range
- 3) Inverter Indicator (Green) : "On" means when load is powered by inverter, "Off" means when it is not working and blinking means it is in overload condition.
- 4) Bypass Indicator (Green) : "On" means when UPS is in bypass mode, "Off" means not in bypass mode and blinking means when the input is beyond normal range
- 5) Battery Indicator (Green) : On: when UPS is in battery mode, Off: Not in Battery mode; Blinking: when battery voltage is low or battery is not connected
- 6) Output Indicator (Green) : On: when there is output, Off: no output.

File name	Date	Page	Code	PUV9E010/15/20-AK
DF19010A	10/04/2019	15 di 28		

2. LCD display content

1) Running parameters

Input voltage/frequency, output voltage/frequency/current, temperature inside, UPS, battery remaining capacity, battery charging/fully charged, battery voltage.

2) Alarm information (priority from high to low)

It provides shutting down, auxiliary power fault, output short circuit, inverter fault, rectifier fault, over temperature, overload, charger fault, battery fault, battery capacity low, ready to shut down and output fault.

3) Parameter setting

Menu setting, floating /boosting charging setting, battery capacity setting, ID of parallel UPS, output voltage/frequency level/calibration.

- 1) Boosting charging voltage 2.30 to 2.35V per cell, floating charging voltage 2.20 to 2.29V per cell
- 2) Battery capacity setting includes the Ah of each battery unit, battery quantity (8 to 10)*2, parallel group number, low battery voltage alarm value (EOD).
- 3) Parallel setting
- 4) UPS ID setting

4) Button Definition

Button	Definition
ON	Switch on the inverter by pressing and holding it for 1s when the UPS is off
OFF	Switch off the inverter output by pressing and holding it for 1s when the UPS is on, load will be powered by bypass output if the bypass is normal
ENT	Confirm the operation
ESC	cancel and go to previous menu
◀	Turn to another menu or parameter
▶	Turn to another menu or parameter

5) UPS Messages reference table

Explanation	Content
Initialization	CurState: Init
No export	No-Out
At bypass	Bypass
Rectifier working	Mains
Battery mode	Battery
Battery testing	Testing
Starting	Starting
ECO mode	CurState: ECO
EPO mode	CurState: EPO
UPS maintaining	CurState: M-Byp
UPS fault	CurState: Fault
Battery float charging	Battery Charging
Battery Boost charging	Battery Boost
Inverter on/off	Invter ON/ Invter OFF
Master of UPS	Inver Master
Maintenance switch close or open	SWMB ON/ SWMB OFF

File name	Date	Page	Code	PUV9E010/15/20-AK
DF19010A	10/04/2019	16 di 28		

3 Display instruction

- 1) The main interface below comes out when the power is connected or the system is cold start. see Fig1

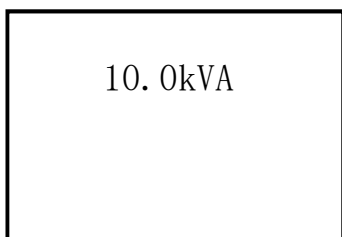

Fig.1: Main interface

- 2) Press ESC/ ◀ or ▶ button, it will change to the basic status interface, see Fig2 below

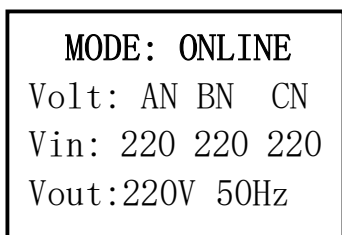

Fig.2: Basic status interface

- 3) Press the ENT button, it will change to main menu, see Fig3,

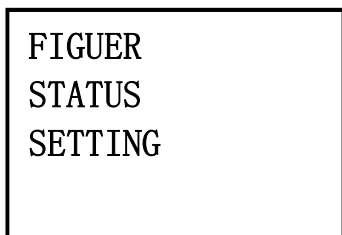

Fig.3: Main menu

- 4) An arrow icon will come out on the LCD when pressing the ENT, then the data info, status info, setting info can be selected by pressing the right or left arrow button, and checking the details by pressing.
- 5) Select and confirm the data info to be viewed in detail. It contains the details of the AC input /output, inverter, battery, BUS, parallel, temperature. See Fig 4 to 13 below.

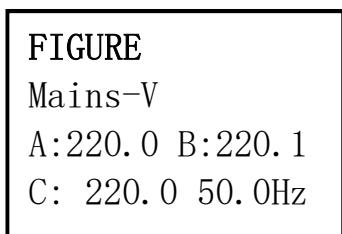

Fig.4: Input volt info

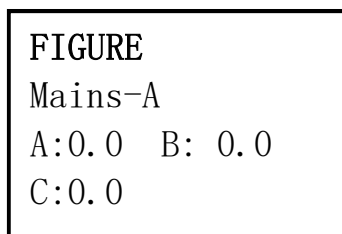

Fig.5: Input current info

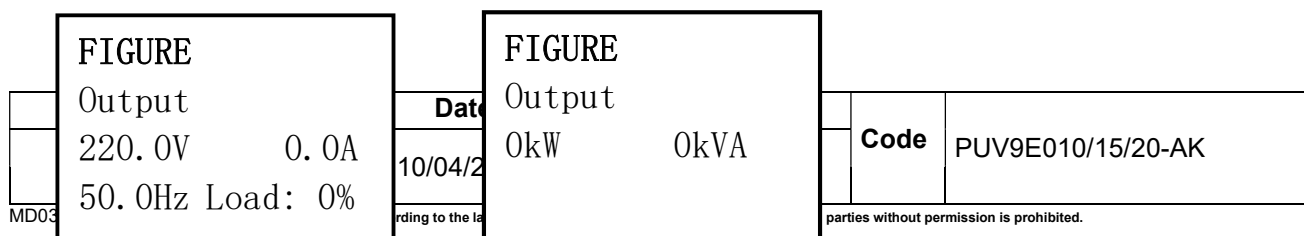

Fig.6: Output info

FIGURE	
Invert	
220.0V	50.0Hz

Fig.7: Output info

FIGURE	
P Battery	
0V	0.0A
0min	0%

FIGURE	
N Battery	
0V	0.0A
0min	0%

Fig.8: Inverter info

FIGURE	
BUS	
-370V	+370V
CAP:	0Hour

Fig.9: Battery info

FIGURE	
Parallel	
ID: 1	
P Amount: 0	

Fig.10 Battery info

FIGURE	
Temperature°C	
PFC:27	INV:27
ENV:27	

Fig.11: Bus info

Fig.12: Parallel info

Fig.13: Temperature info

- 6) Select and confirm the status info can view the details, including status information, alarm information, code, power rating and version. See Fig 14 to 15

STATUS	
Code: 11	
Fault : 0. 0.0.0	
Model: 10.0kVA	

STATUS	
Version	
DSP	
Ver:B006D001	
- - -	

Fig.14: main menu

Fig.15: main menu

- 7) Select and confirm setting menu, setting information will be displayed on the screen, which includes user set, system set, parallel set, battery sett, revise set. See Fig 16 to 24

SETTING	
Mode: NOR	
Batt num: 16	
Batt cap: 7Ah	

SETTING	
V-Level: 220V	
F-Level: 50Hz	

Fig.16: setting menu

Fig.17: setting menu

SETTING	V-upper 15%				
	V-lower -45%	10			
SETTING	Buzzer: Enable				
				Code	PUV9E010/15/20-AK

Fig.18: setting menu

```

SETTING
Parallel set
ID          1
P-amount   2
P-Redund   0
  
```

Fig.19: setting menu

Fig.20: Parallel setting

```

SETTING
BatTest: Off
  
```

Fig.21: Batter self-Test Off

```

SETTING
BatTest: |10s
  
```

Fig.22: Batter self-Test ON : to 10 seconds

```

SETTING
BatTest: |10m
  
```

Fig.23: Batter self-Test ON: to 10 minutes

```

SETTING
BatTest: |EOD
  
```

Fig.24: Batter self-Test ON: to EOD

File name	Date	Page	Code	PUV9E010/15/20-AK
DF19010A	10/04/2019	19 di 28		

6.3 Working Mode and transferring

Usually, the UPS should be set to work in AC mode, so it will transfer to battery mode automatically without interruption when AC fails. When the UPS is overloaded, it will transfer to bypass mode without interruption. When the inverter is defective or over temperature occurred inside the UPS, the UPS will transfer to bypass mode if the bypass is normal.

6.3.1 Transfer to bypass if overload

When the load of UPS is beyond normal range and lasts for the time set, it will transfer to bypass mode and beeps twice every second, then the load is powered by AC directly. Please decrease the load immediately until the alarm is eliminated. The UPS will start the inverter after 5 minutes. In order to protect the load and the UPS, it is required to set the limitation times of transferring to bypass mode due to overload in 1 hour. If it exceeds the limitation times set, the UPS will keep in bypass mode.

6.3.2 Normal mode to battery mode

The UPS will go to battery mode if the AC is failed. The UPS will shut down automatically if batteries are drained. When AC recovers, the UPS will start the inverter automatically.

6.3.3 Go to bypass mode due to over temperature

The temperature inside UPS may be high if ambient temperature is high or the ventilation is poor, then the UPS will go to Bypass mode, fault indicator will be on (red), the LCD will display that the inner temperature is high, long beeps will come. If so, please cut off the input power of the UPS, move objects that affecting the ventilation far from the UPS if any or increase the distance between the UPS and the wall. Wait until the UPS temperature becomes normal then restart it.

6.3.4 Output short circuit

When the UPS output is in short circuit, the UPS will cut off the output, fault indicator will be on (red), the LCD will display output is in short circuit, long beeps come. If so, please disconnect the load in short circuit, cut off the UPS input power and wait for 10mins, the UPS will shut down automatically or press the off button to shut down in after 10s. Before restarting the UPS, please make sure that the short circuit problem has been solved.

6.3.5 Batter self-Test

The page is the introduction to the Battery self-test setting. The default Settings is "OFF" when the UPS has no need of the battery self-test function. When turn to "ON", batteries can do the self-test automatically per 30 days. Three kinds of Battery Self-test Time can be choosing as below.

When choosing 10s, UPS can transfer to Battery Mode automatically per 30 days. And the Battery Self-test Time is 10 seconds.

When choosing 10m, UPS can transfer to Battery Mode automatically per 30 days. And the Battery Self-test Time is 10 minutes.

When choosing EOD UPS can transfer to Battery Mode automatically per 30 days. And the Battery Self-test Time is EOD.

6.4 UPS monitoring

Please refer to the instruction of the UPS monitoring software provided.

6.5 Display Messages/ Records

This section lists the event and alarm messages that the UPS might display. The messages are listed in alphabetical order. This section is listed with each alarm message to help you troubleshoot problems

File name	Date	Page	Code	PUV9E010/15/20-AK
DF19010A	10/04/2019	20 di 28		

6.5.1 Operational Status and Mode(s)

item	Content Displayed	LED			
		Fault	Bypass	Battery	Inverter
1	Initialized	EXTINGUISH	EXTINGUISH	EXTINGUISH	EXTINGUISH
2	Standby Mode	EXTINGUISH	EXTINGUISH	X	EXTINGUISH
3	No Output	EXTINGUISH	EXTINGUISH	X	EXTINGUISH
4	Bypass Mode	EXTINGUISH	LIGHT	X	EXTINGUISH
5	Utility Mode	EXTINGUISH	EXTINGUISH	X	LIGHT
6	Battery Mode	EXTINGUISH	EXTINGUISH	LIGHT	EXTINGUISH
7	Battery Self-diagnostics	EXTINGUISH	EXTINGUISH	LIGHT	EXTINGUISH
8	Inverter is starting up	EXTINGUISH	X	X	EXTINGUISH
9	ECO Mode	EXTINGUISH	X	X	X
10	EPO Mode	LIGHT	EXTINGUISH	X	EXTINGUISH
11	Maintenance Bypass Mode	EXTINGUISH	EXTINGUISH	EXTINGUISH	EXTINGUISH
12	Fault Mode	LIGHT	X	X	X

Note: "X" shows that it will be determined by other conditions.

6.5.2 Alarm Information

Item	UPS Alarm Warning	Buzz	LED
1	Rectifier Fault	Beep continuously	Fault LED lit
2	Inverter fault	Beep continuously	Fault LED lit
3	Inverter Thyristor short	Beep continuously	Fault LED lit
4	Inverter Thyristor broken	Beep continuously	Fault LED lit
5	Bypass Thyristor short	Beep continuously	Fault LED lit
6	Bypass Thyristor broken	Beep continuously	Fault LED lit
7	Fuse broken (Reserved)	Beep continuously	Fault LED lit
8	Parallel relay fault	Beep continuously	Fault LED lit
9	Fan fault	Beep continuously	Fault LED lit
10	Reserved	Beep continuously	Fault LED lit
11	Auxiliary power fault	Beep continuously	Fault LED lit
12	Initialization fault	Beep continuously	Fault LED lit
13	P-Battery Charger fault	Beep continuously	Fault LED lit
14	N-Battery Charger fault	Beep continuously	Fault LED lit
15	DC Bus over voltage	Beep continuously	Fault LED lit
16	DC Bus below voltage	Beep continuously	Fault LED lit
17	DC bus unbalance	Beep continuously	Fault LED lit
18	Soft start failed	Beep continuously	Fault LED lit
19	Rectifier Over Temperature	Twice per second	Fault LED lit
20	Inverter Over temperature	Twice per second	Fault LED lit
21	Input N loss	Twice per second	Fault LED lit

File name	Date	Page	Code	PUV9E010/15/20-AK
DF19010A	10/04/2019	21 di 28		



Item	UPS Alarm Warning	Buzz	LED
22	Battery reverse	Twice per second	Fault LED lit
23	Cable connection error	Twice per second	Fault LED lit
24	CAN comm. Fault	Twice per second	Fault LED lit
25	Parallel load sharing fault	Twice per second	Fault LED lit
26	Battery over voltage	Once per second	Fault LED blinking
27	Mains volt. reverse (Reserved)	Once per second	Fault LED blinking
28	Bypass reverse (Reserved)	Once per second	Fault LED blinking
29	Output Short-circuit	Once per second	Fault LED blinking
30	Rectifier over current	Once per second	Fault LED blinking
31	Bypass over current	Once per second	BPS LED blinking
32	Overload	Once per second	INV or BPS blinking
33	No battery	Once per second	BATTERY blinking
34	Battery under voltage	Once per second	BATTERY blinking
35	Battery low pre-warning	Once per second	BATTERY blinking
36	Internal Communication Error	Once per second	Bypass LED lit
37	DC component over limit.	Once per 2 seconds	INV blinking
38	Parallel Overload	Once per 2 seconds	INV blinking
39	Mains volt. Abnormal	Once per 2 seconds	BATTERY LED lit
40	Mains freq. abnormal	Once per 2 seconds	BATTERY LED lit
41	Bypass Not Available		BPS blinking
42	Bypass unable to trace		BPS blinking
43	Boot is invalid		

File name	Date	Page	Code	PUV9E010/15/20-AK
DF19010A	10/04/2019	22 di 28		



7 Specification

Product Performance

CAPACITY		10kVA/9kW、15kVA/13.5kW、20kVA/18kW PF:0.9
MODEL		10K(S/H)/15K(H)/20K(H)
AC INPUT	INPUT	3 phase 5 wires
	Input power factor	≥ 0.99
	Rated voltage	220Vac/230/240Vac (self-adaption)
	Rated frequency	50Hz/60Hz (settable)
	Voltage range	208~478V
	Frequency range	45~55Hz (50 Hz) ; 55~65Hz (60 Hz)
	Bypass voltage range	Max: 220V, +25%(+10%,+15%,+20%, optional) 230V, +20%(+10%,+15%, optional) 240V, +15%(+10%, optional) Min: -45% (-20%, -30%, optional)
Bypass frequency range	±1%、±2%、±4%、±5%、±10%	
DC INPUT	Battery number	16/18/20 pieces
	Battery type	VRLA
	Charge model	Boost charge or float charge auto switch
	Charge time	Boost charge up to 20 hour (Max)
	Charge current (MAX.)	1A (S) /10A (H)
AC OUTPUT	Output type	1 phase 3 wires
	Voltage regulation	±1.0%
	Voltage distortion (THD)	less than 2% at 100% liner load
		less than 5% at 100% non-liner load
	Output voltage class	220/230/240V±1%
	Frequency regulation	±0.1% (single machine)
		±0.25% (parallel operation)
	Frequency	50/60±0.1Hz 【Utility Mode: tracking A phase frequency, > ±10% (±1%、±2%、±4%、±5%)】
		50Hz/60±0.1Hz 【Battery Mode】
Frequency track speed	1Hz/s (single machine)	
	0.5Hz/s (parallel operation)	
load capacity (Mains, drop a level in battery mode)	≤110%, lasts 1 hour ≤125%, lasts 10 minutes ≤150%, lasts 1 minute > 150%, switch to bypass	

File name	Date	Page	Code	PUV9E010/15/20-AK
DF19010A	10/04/2019	23 di 28		



	load capacity	>95%, cannot inverter-fed
		Load for a long time when rated output current under 125%
		Bypass load capacity is controlled by bypass circuit breaker, tripping when circuit breaker operating current.
	Crest factor	3:1
	Efficiency at AC	10K: ≥90% 15K/20K: ≥92%
	Dynamic respond	5.0%
	Dynamic respond	40ms
	output voltage DC component	≤100mV
Transfer time	Between Normal and battery mode	0ms
	Between inverter and bypass	0ms(synchronous) <15ms (50Hz), <13.33ms (60Hz) (asynchronous)
	Noise	<55dB (1m)
	Display	LCD+LED
	Safety	Meet up with STANDARD IEC62040-1
	Max input voltage	320Vac, 1 hour (static)
	EMI	Conduction: IEC 62040-2
		Radiation: IEC 62040-2
		Harmonics: IEC 62040-2
	EMS	IEC 62040-2
	MTBF	250,000 hours
	Isolation resistance	> 2MΩ (500Vdc)
	Isolation intension	2820Vdc, <3.5mA, 1min
	Surge	Meeting up with IEC60664-1,1.2/50uS+8/20uS, composite wave ability ≥ 6kV/3kA.
	Protection	IP20

Dimension and weight

Mechanical Characteristics			
Rated power	kVA	10kVA(S)	10kVA/15kVA/20kVA(H)
Height	mm	655	616
Width	mm	250	250
Depth	mm	597	502
N.W.	kg	76	10kVA:35,15/20kVA:45
Color			Black

File name	Date	Page	Code	PUV9E010/15/20-AK
DF19010A	10/04/2019	24 di 28		

8 Maintenance

Please follow 2.2.1 to install the UPS

8.1 Fan maintenance

Continual working time of fan is 20000 to 40000 hours. It will be shorter as temperature raises. Please check the fan periodically, make sure there is wind blowing out from it.

8.2 Battery maintenance

There are sealed lead acid maintenance free batteries inside this series standard models. Battery life depends on environment temperature and discharge/charge cycles, it will be shortened if temperature raised or deep discharged. Periodical maintenance is required so as to keep battery in good condition.

- 1) The most proper working temperature is 15 to 25 Celsius degree.
- 2) Avoid small discharging current. Don't let UPS work in battery mode continuously for 24 hours.
- 3) Charge battery for at least 12 hours every 3 months if it is free of operation. If the environment temperature is high, charge it once every 2 months.
- 4) For extended backup models, check and clean the battery connectors periodically. .

If backup time has become much less than before, or there is battery fault displayed on the LCD, please contact distributors to confirm whether the batteries are needed to be replaced or not.

CAUTION:

- ★Before replacing batteries, first please turn off the UPS and break off the mains. Remove your metallic adornment such as finger ring, watch and so on.
- ★When replace batteries, please use the screwdriver with insulating handle. Do not lay the tools or metallic goods on the battery.
- ★Never reverse or short circuit between the battery anode and cathode.

8.3 Visual checking

- 1) Clean your UPS regularly, especially intake and exhaust vents to Keep ventilation of the UPS in good condition. Use a vacuum cleaner to clean up when necessary.
- 2) Check nothing blocks the ventilation of the front, rear and side panel and the case bottom.

8.4 UPS status checking

- 1) Check to see if there is any fault occurred, fault indicator is on or any alarm there.
- 2) Please find the cause if the UPS is working in bypass mode.
- 3) If the UPS is working in battery mode, make sure it is normal; on the contrary, please find out the root cause, such as Utility Failure or self-check of battery.

File name	Date	Page	Code	PUV9E010/15/20-AK
DF19010A	10/04/2019	25 di 28		

9 Trouble shooting

When your UPS has the abnormal situation, please refer to the below table for checking and troubleshooting first.

Please contact the distributor if problems cannot be solved by the trouble shooting below

No.	Problem description	Probable causes	Solution
1	No display on the LCD, no self- diagnostics	A Input power absent B Low input	Use Multi-meter to measure the input to see if it is normal or not.
2	AC normal but AC indicator off, the UPS is in battery mode	A Input circuit breaker off. B Input power connection problem	A Switch on the input breaker B Check the connection and re-do
3	No alarm but no output	Output connection problem	Check the connection and re-do
4	The UPS doesn't start after pressing On button	A pressing ON button time is insufficient B Overload	A Press and hold On button for 1s B Disconnect all loads and restart
5	AC indicator blinking	Input AC is beyond normal range	Pay attention to the backup time if the UPS is in battery mode
6	Abnormal backup time	A Battery not fully charged B Battery Bad	A Charge battery for 8 hours when AC is normal, then test the backup time again B Contact distributor to replace battery
7	Abnormal sound or smell	Fault inside UPS	shut down the UPS immediately and Contact distributor

Please provide the UPS model, SN when calling distributor for maintenance.

File name	Date	Page	Code	PUV9E010/15/20-AK
DF19010A	10/04/2019	26 di 28		

10 Appendix I USB communication port definition

Definition of Male port:

1	2
4	3

Pin 1 VCC, Pin 2 D-
pin 3 D+, Pin 4 GND

Application: use UPSilon2000 Power Management software

Available functions of the USB

- Monitor UPS power status
- Monitor UPS alarm info
- Monitor UPS running parameters
- Timing off/on setting

File name	Date	Page	Code	PUV9E010/15/20-AK
DF19010A	10/04/2019	27 di 28		

11 Appendix II RS232 communication port definition

Definition of Male port:

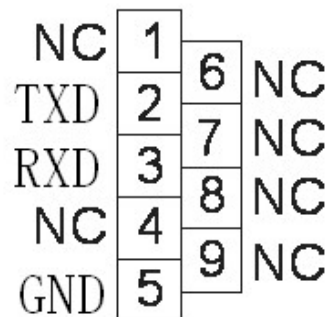

Connection between PC RS232 port and UPS RS232 port:

PC RS232 port	UPS RS232 port	
Pin 2	Pin 2	UPS send, PC receive
Pin 3	Pin 3	PC send, UPS receive
Pin 5	Pin 5	ground

Available function of RS232:

- ◆ Monitor UPS power status.
- ◆ Monitor UPS alarm info.
- ◆ Monitor UPS running parameters.
- ◆ Timing off/on setting.

RS-232 communication data format:

Baud rate ----- 2400bps

Byte length ----- 8bit

End bit ----- 1bit

Parity check -----none

File name	Date	Page	Code	PUV9E010/15/20-AK
DF19010A	10/04/2019	28 di 28		