

12V 100Ah – MBESL022 - AGM Battery



The battery is constructed by plates, separators, safety valves and container. Since the electrolyte is held by a glass mat separator and plates, the battery can use in any direction and position without leakage.

Performance Characteristics

Nominal Voltage	12V
Number of cell	6
Life (Year)	10years
Nominal Capacity 77°F(25°C)	
20-hour rate(5.0A,10.5V)	100Ah
10-hour rate(9.27A,10.5V)	92.7Ah
5-hour rate (17.2A,10.5V)	86.0Ah
1-hour rate(65A,9.6V)	65Ah
Internal Resistance	
Fully Charged battery 77°F(25°C)	5mΩ
Self-Discharge	
3% of capacity declined per month at 20°C(average)	
Operation Temperature Range	
Discharge	-20~60°C
Charge	-10~60°C
Storage	-20~60°C
Max. Discharge Current 77°F(25°C)	600A(5s)

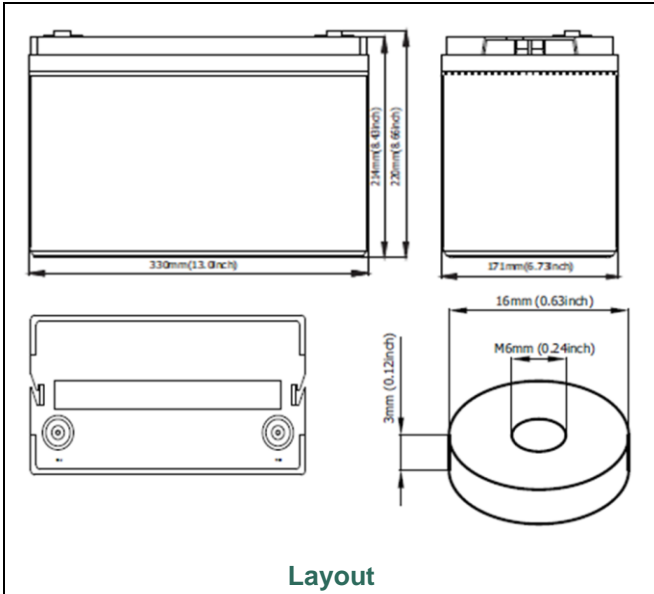

Dimensions and Weight (+/- 2mm)

Length (mm / inch)	330 / 12.95
Width (mm / inch)	171 / 6.77
Height (mm / inch)	214 / 8.46
Total Height (mm / inch)	224 / 8.82
Approx. Weight(Kg / lbs).....	30.0 / 66.0

Discharge Constant Current (Amperes at 77°F25°C)

F.V/Time	5min	10min	15min	30min	45min	3h	5h	10h	20h
9.60V	326	224	177	109	65.7	26.4	18.5	10.3	5.35
10.20V	310	213	170	105	63.0	26.0	18.2	10.2	5.35
10.80V	291	200	161	99.5	59.9	25.5	17.8	10.0	5.30

Discharge Constant Power (Watts at 77°F25°C)

F.V/Time	5min	10min	15min	30min	45min	3h	5h	10h	20h
9.60V	3423	2419	1943	1223	749	310	219	123	64.2
10.20V	3252	2298	1866	1174	719	306	215	122	64.2
10.80V	3057	2160	1772	1115	683	300	210	119	63.6



Battery Construction

COMPONENT	Positive	Negative	Container	Cover	Safety valve	Terminal	Separator	Electrolyte
RAW MATERIAL	Lead dioxide	Lead	ABS	ABS	Rubber	Copper	Fiberglass	Sulfuric acid

Charging Methods

Application	Charging method	Charging Voltage at 25° C	Temperature compensation coefficient of charging voltage	Max. charging current	Charging time 25°C(h)		Temp (° C)
					100% discharge	50% discharge	
For standby power source	Constant voltage & Constant Current Charging (with current restriction)	13.4-13.8V	-18 mV/° C	30A	24	20	0~40 (32~104° F)
For cycle service		14.5-15.0V	-30 mV/° C	30A	16	10	

*Temperature compensation of charging voltage is not needed. When using the batteries within 15° C to 35° C range.

